

# Math 0300 Review Sheet

Revised: Fall 2009

Name: \_\_\_\_\_

Section: \_\_\_\_\_

This review is comprehensive but should not be the only material used to study for the final exam. It should not be considered a preview of the final exam. It does not substitute for studying previous tests, quizzes, homework, class notes, text discussions, etc. There may be questions on the final exam unlike questions on this review, and vice versa. No question on this review will be exactly duplicated on the final exam. This review is longer than the final exam. You may have your work checked and ask questions on working the review sheet in the Math Lab located in 925-N.

1. Given the set  $\left\{-20, -\sqrt{3}, -1, 0, 0.25, \frac{14}{2}, \sqrt{64}, \frac{1}{0}, \frac{2}{6}, \frac{0}{5}, \sqrt{19}, \pi\right\}$  list the numbers from the set that are

- |                      |                        |
|----------------------|------------------------|
| (a) Natural Numbers  | (e) Irrational Numbers |
| (b) Whole Numbers    | (f) Real Numbers       |
| (c) Integers         | (g) Undefined          |
| (d) Rational Numbers |                        |

2. Insert one of the symbols = , < , or > to make a true statement.

- |                                       |   |
|---------------------------------------|---|
| (a) $-3 \square -1$                   | (b) $ -5  \square  5 $                  |
| (c) $- -2  \square  -2 $              | (d) $\frac{12}{4} \square \frac{15}{5}$ |
| (e) $7 + \frac{12}{2} \square 13 - 7$ |   |

3. Simplify each of the following expressions.

- |                                      |   |
|--------------------------------------|---|
| (a) $\frac{2}{7} \cdot 14$           | (i) $2 + 3(13 - 9) - (12 \div 3)$           |
| (b) $\frac{10}{15} \div 2$           | (j) $ -9 + 3  + (-3)$                       |
| (c) $\frac{7}{3} \cdot \frac{9}{14}$ | (k) $4(x + 1) - 3(x - 2)$                   |
| (d) $\frac{7}{3} \div \frac{1}{15}$  | (l) $15 - 3 \cdot 2$                        |
| (e) $\frac{7}{3} + \frac{8}{3}$      | (m) $4 \div 2 \cdot 3 + 5$                  |
| (f) $\frac{7}{3} + \frac{8}{15}$     | (n) $\frac{2}{7}(6 + 1) - 2$                |
| (g) $\frac{10}{3} - \frac{8}{3}$     | (o) $-2^2 + (2 - 2)^3 - 10$                 |
| (h) $\frac{7}{3} - \frac{8}{15}$     | (p) $\frac{3^3 - 5^2 + (3 - 1)^2}{2^3 - 5}$ |

**4. Evaluate each of the following expressions.**

(a)  $-|5x - 3y|$  if  $x = 2$  and  $y = 3$

(b)  $\frac{2(z + 3y)}{-(x + y)}$  if  $x = -1$ ,  $y = -2$ , and  $z = -3$

**5. State the property of real numbers that justifies the following statements.**

(a)  $x(y + z) = xy + xz$

(c)  $x(yz) = (yz)x$

(b)  $x \cdot 1 = x$

(d)  $x + (y + z) = (y + z) + x$

**6. State the additive inverse (opposite) of each number given.**

(a)  $-5$

(b)  $\frac{3}{2}$

(c)  $2$

**7. State the multiplicative inverse (reciprocal) of each number given.**

(a)  $-5$

(b)  $\frac{3}{2}$

(c)  $2$

**8. Write an expression that represents each of the following statements.**

(a) The number obtained when three times  $x$  is subtracted from the sum of  $y$  and  $z$ .

(b) The quotient obtained when the sum of the three numbers  $x$ ,  $y$ , and  $z$  is divided by their product.

**9. Simplify by combining like terms, if possible.**

(a)  $2x - 4 + 3x$

(c)  $5x^2 + 5y^2$

(b)  $-3(x - 3) + 2x$

(d)  $5xy^2 + 2xy^2 + 2xy^2 - 6xy$

**10. Solve each equation, if possible.**

(a)  $1 = y - 5$

(f)  $2(3 - 2x) = 3(2 - x) + 8$

(b)  $c - 11 = 22$

(g)  $5 + 9y - 3 = 5(2 + y) + 5$

(c)  $-13x = 26$

(h)  $8a + 3(2 - a) = 5(a + 2) - 4$

(d)  $4 = \frac{x}{5}$

(i)  $2(s + 2) = 2(s + 1) - 3$

(e)  $\frac{3y - 5}{7} = 1$

(j)  $\frac{4x - 9}{3} = 3x - 8$

**11. Solve the formula for the variable indicated. Find the value of the specified variable in (c) and (d).**

(a)  $A = \pi r^2 h$  for  $h$

(c)  $y = mx + b$  for  $b$ , find the value of  $b$  if  $y = 6$ ,  $m = -2$ , and  $x = 1$

(b)  $A = B - Brs$  for  $s$

(d)  $P = 2l + 2w$  for  $l$ , find the value of  $l$ , if  $P = 20$  and  $w = 5$

**12. Solve the following word problems.**

(a) The width of a rectangle is 7 cm less than its length, and the perimeter is 30 cm. What is the length?

(b) Twice a number decreased by 1 is equal to Three times the number increased by 3. What is the number?

(c) The sum of two consecutive numbers is 27. Find the two numbers.

**13. Solve the following percent problems.**

(a) 357 is 85% of what number?

(b) 15% of what number is 48?

(c) 20 is what percent of 80?

(d) What number is 30% of 150?

14. Solve the following inequalities. Graph the solution set on a number line and indicate the solution set in interval notation.

- (a)  $3x + 5 \leq 8$
- (b)  $-5(x + 1) > 2x + 9$
- (c)  $-5 < 5(x + 7) < 10$
- (d)  $0 \leq 3x + 12 \leq 18$

15. Read the following graphs and answer the question.

(a)

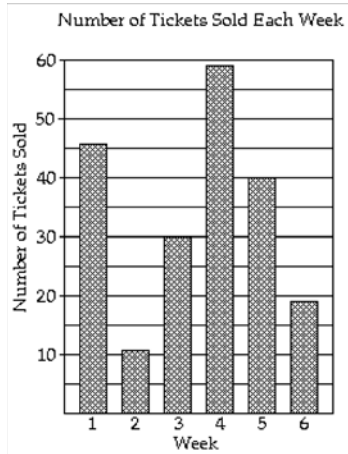

- 1) During which week were the greatest number of tickets sold?
- 2) During which weeks were the number of tickets sold less than 35?

(b)

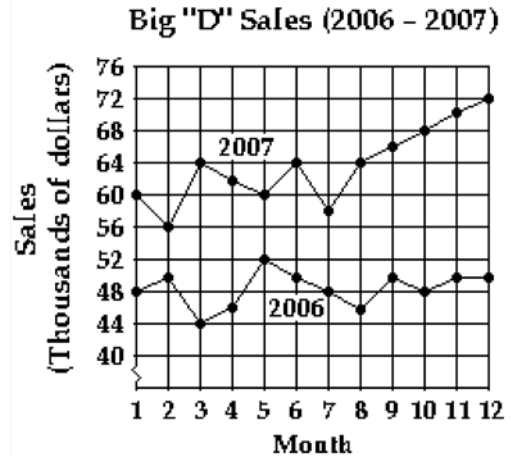

- (1) Which month in 2007 had the highest sales?
- (2) When was the first time in 2006 that sales reached above 48,000?

16. Determine the coordinates of the ordered pairs on graph and plot ordered pairs on the coordinate plane.

(a)

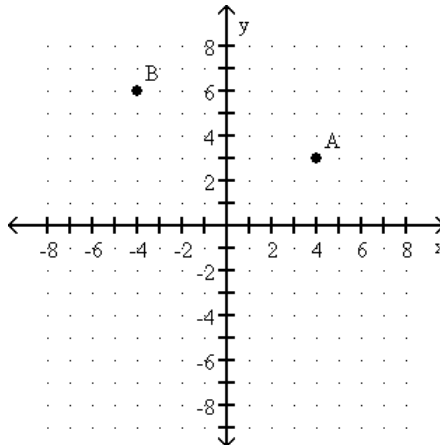

Point A:  
Point B:

(b)

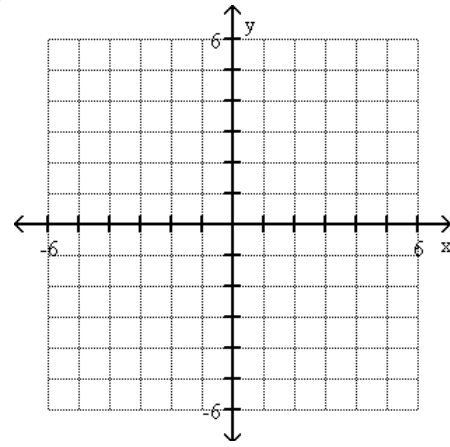

Point A: (-1, -2)  
Point B: (0, -5)

17. Graph the following equations on the coordinate plane provided.

(a)  $2x - 3y = 6$

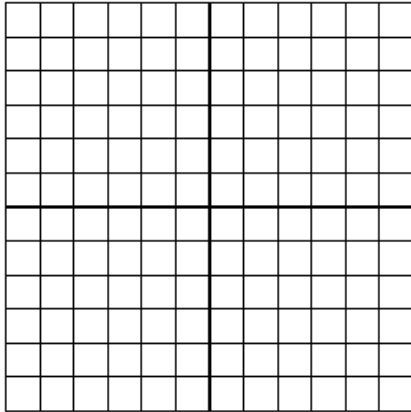

(d)  $-2x = 8$

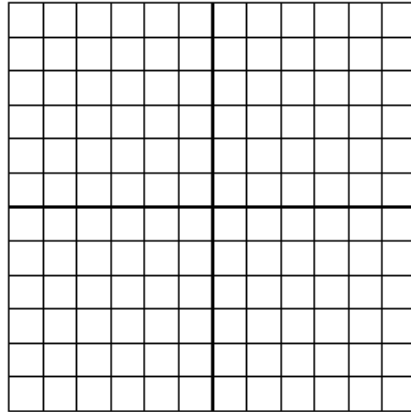

(b)  $4y = 8$

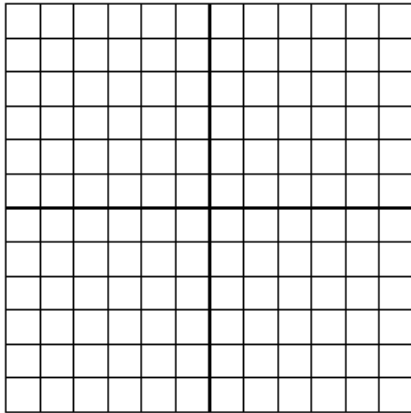

(e)  $x + y = 3$

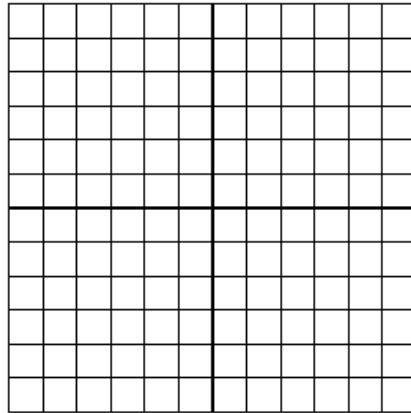

(c)  $y = 3x + 4$

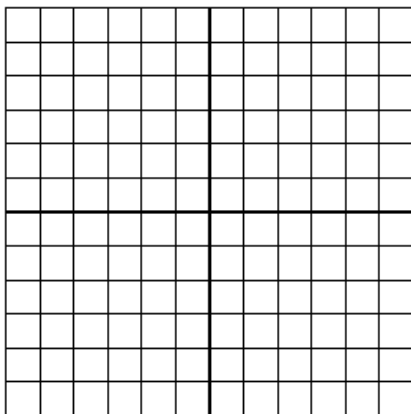

(f)  $-3x - 5y = -15$

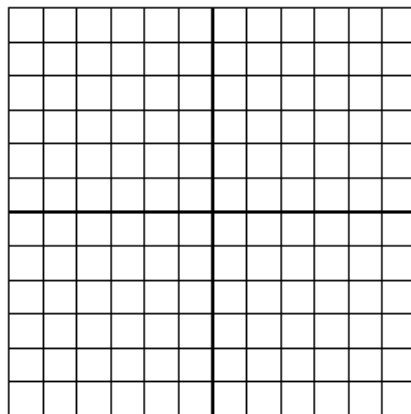

18. Identify the  $x$ - and  $y$ -intercepts of the following graphs or equations.

(a)

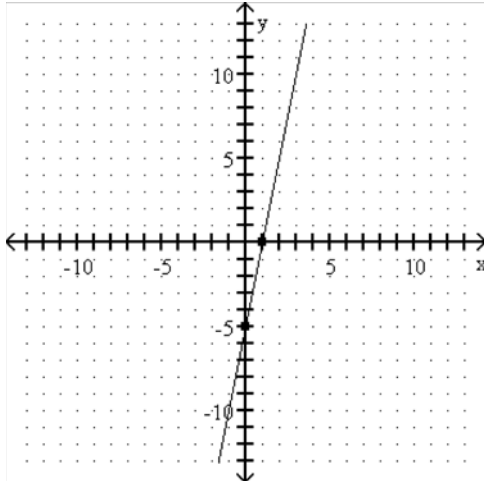

(b)

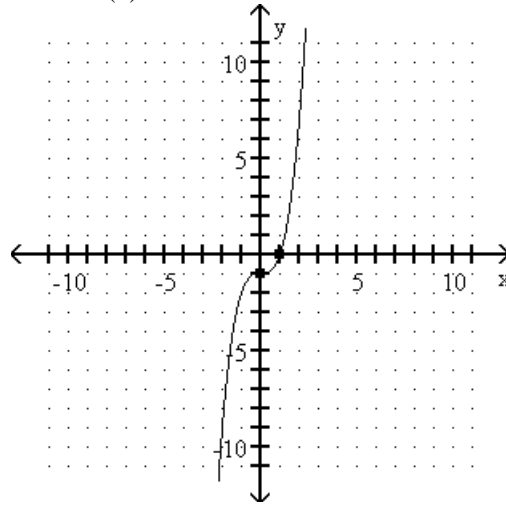

(c) Find the  $x$ -intercept of the line given by the equation  $3x + 2y = 6$ .

(d) Find the  $y$ -intercept of the line given by the equation  $3x + 2y = 6$ .

19. Find the slope of each line through the given points.

(a)  $(1, 3)$  and  $(5, -13)$

(c)  $(1, 3)$  and  $(1, 2)$

(b)  $(0, -2)$  and  $(5, -1)$

(d)  $(1, 3)$  and  $(5, 3)$

20. Determine if the following lines are parallel, perpendicular, or neither.

(a)  $y = \frac{1}{5}x + 2$  and  $y = -5x + 2$

(b)  $2y = -3x$  and  $-3x + 2y = 5$

(c)  $2x + y = 2$  and  $y = \frac{1}{2}x + 2$

(d)  $5x - 2y = 4$  and  $y = \frac{5}{2}x + 2$

(e)  $y = 4$  and  $x = 2$

21. Evaluate the following functions for the given value.

(a)  $f(x) = -6x - 2$ , evaluate  $f(1)$

(b)  $f(x) = 2x^2 + 6x + 1$ , evaluate  $f(-2)$ .

(c)  $g(x) = 2x^2 + 6x + 1$ , evaluate  $g(0)$ .

22. Determine if the following graphs are function using the vertical line test.

(a)

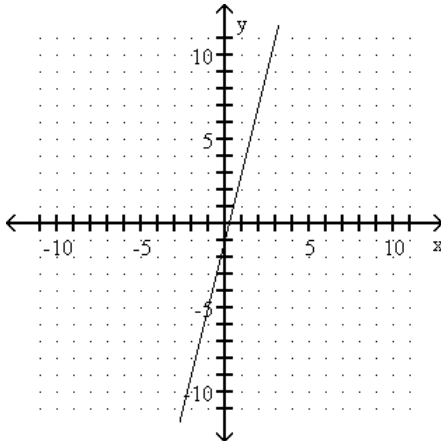

(b)

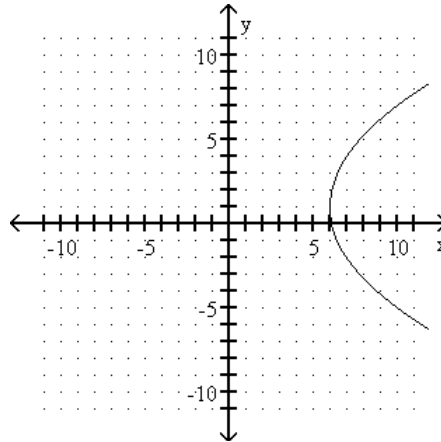

23. Determine the domain and/or range, as indicated, of the following different types of representations of functions.

(a)

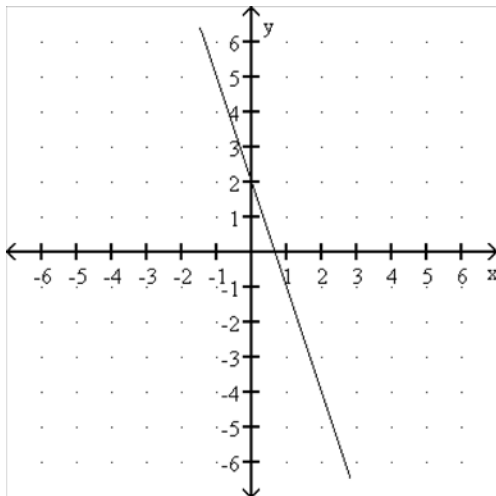

Find the domain and range in interval notation.

Domain:                      Range:

(b)

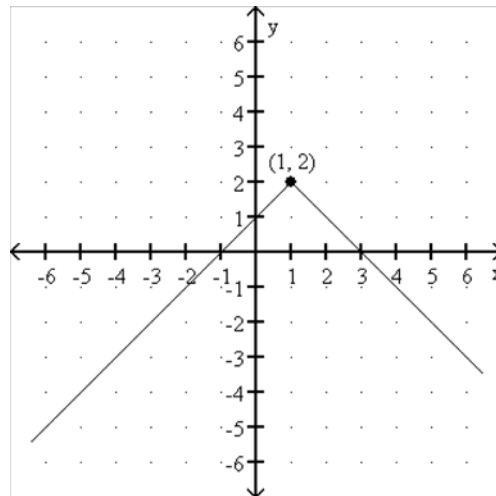

Find the domain and range in interval notation.

Domain:                      Range:

(c)  $\{(1, 2), (2, 3), (3, 4), (4, 5)\}$

Find the domain and range in set roster notation.

Domain:

Range:

(d)  $\{(0, -1), (-2, 0), (-3, 0), (-4, 4)\}$

Find the domain and range in set roster notation.

Domain:

Range:

(e)  $f(x) = 3x + 1$

Find the domain and range in set-builder notation.

Domain:

(f)  $f(x) = \frac{3x - 5}{2x + 1}$

Find the domain and range in set-builder notation.

Domain:

**24. Solve the following systems of equations.**

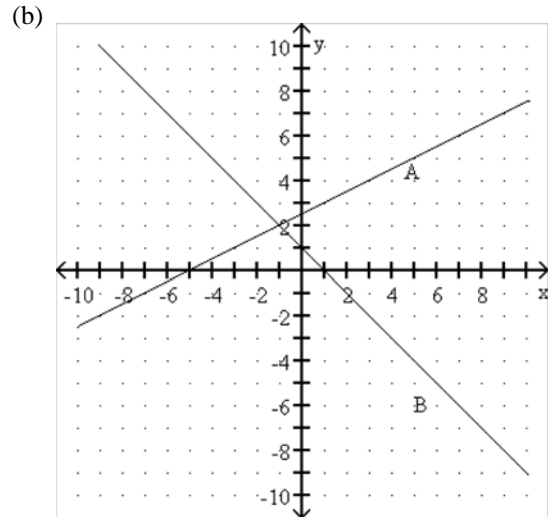
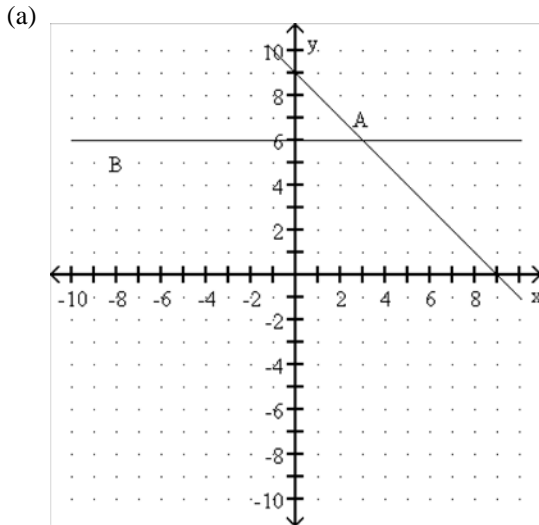

(c) 
$$\begin{cases} x = 7 \\ 3x + 2y = 5 \end{cases}$$

(d) 
$$\begin{cases} y = 2x - 7 \\ 2x - y = 3 \end{cases}$$

(e) 
$$\begin{cases} x - y = 10 \\ x + y = 6 \end{cases}$$

(f) 
$$\begin{cases} 5x - 2y = 7 \\ 6x + y = -7 \end{cases}$$

**25. Set up the following system of equations but DO NOT SOLVE.**

- (a) The sum of two numbers is 12, and their difference is 2. Find the two numbers. (Let  $x$  represent the first number and  $y$  represent the second number.)  
 (b) The sum of two numbers is  $-5$ . Three times the first number equals 4 times the second number. Find the two numbers. (Let  $x$  represent the first number and  $y$  represent the second number.)

**26. State the degree and the leading coefficient of the following polynomials.**

- (a)  $5x - 9x^5$ .  
 (b)  $19x^3y^7 + 3x^5y^8 - 1$ .

**27. Perform the indicated operations and simplify, if possible.**

- (a)  $(9x + 5) + (3x - 2)$                       (b)  $(7x^2 + 9) + (5x + 2)$   
 (c)  $(7x^2 + 9x + 5) + (3x^2 - 3x - 2)$       (d)  $(9x + 5) - (3x + 2)$   
 (e)  $(7x^2 - 9) - (5x - 2)$                       (f)  $(7x^2 + 9x + 5) - (3x^2 - 3x - 2)$   
 (g)  $x^3(2x^2 + 5x)$                                   (h)  $(x + 3)(x + 2)$   
 (i)  $(3x - 2)(3x + 4)$                               (j)  $(x + 5y)(5x - y)$   
 (k)  $(x - 2)^2$     (l)  $(x + 3)(x - 3)$   
 (m)  $\frac{18r - 15st}{3rst}$     (n)  $\frac{8x^2y - 5xy + 4y^2}{4xy}$

**28. Convert each Standard Notation to Scientific Notation**

(a) 37,000

(b) 0.000045

**29. Convert each Scientific Notation to Standard Notation**

(a)  $9.7 \times 10^4$

(b)  $9.7 \times 10^{-5}$

**30. Simplify the following exponential expressions.**

(a)  $-3(5^3 - 3^3)$

(g)  $x x^2 x^3 x^4 x^5$

(b)  $(-3a^3)(2a)(-a)^2$

(h)  $3^{-2}$

(c)  $(z^{-2}z^5)^4$

(i)  $(-5a)^0$

(d)  $2y^{-5}$

(j)  $(3y)^2(y^3)^2$

(e)  $\left(\frac{x^2}{y}\right)^{-2}$

(k)  $\left(\frac{3a^2b}{ab^2}\right)^3$

(f)  $\left(\frac{3a^5b^2}{a^{-3}b^{-4}}\right)^4$

(l)  $\left(\frac{z^2 \cdot z^4}{z^3}\right)^5$

**ANSWERS:**

1. (a)  $\frac{14}{2}, \sqrt{64}$

(b)  $0, \frac{14}{2}, \sqrt{64}, \frac{0}{5}$

(c)  $-20, -1, 0, \frac{14}{2}, \sqrt{64}, \frac{0}{5}$

(d)  $-20, -1, 0, 0.25, \frac{14}{2}, \sqrt{64}, \frac{0}{5}, \frac{2}{6}$

(e)  $\pi, \sqrt{19}, -\sqrt{3}$

(f)  $-20, -\sqrt{3}, -1, 0, 0.25, \frac{14}{2}, \sqrt{64}, \frac{0}{5}, \sqrt{19}, \frac{2}{6}, \pi$

(g)  $\frac{1}{0}$

2. (a)  $<$

(b)  $=$

(c)  $<$

(d)  $=$

(e)  $>$

3. (a) 4

(b)  $\frac{1}{3}$

(c)  $\frac{3}{2}$

(d) 35

(e) 5

(f)  $\frac{43}{15}$

(g)  $\frac{2}{3}$

(h)  $\frac{9}{5}$

(i) 10

(j) 3

(k)  $x + 10$

(l) 9

(m) 11

(n) 0

(o) -14

(p) 2

4. (a) -1

(b) -6

5. (a) Distributive Property

(b) Identity Element for Multiplication

(c) Commutative Property for multiplication

(d) Commutative Property for addition

6. (a) 5

(b)  $-\frac{3}{2}$

(c) -2

7. (a)  $-\frac{1}{5}$

(b)  $\frac{2}{3}$

(c)  $\frac{1}{2}$

8. (a)  $(y + x) - 3x$

(b)  $\frac{x+y+z}{xyz}$

9. (a)  $5x - 4$

(b)  $-x + 9$

(c)  $5x^2 + 5y^2$

(d)  $9xy^2 - 6xy$

10. (a)  $y = 6$

(b)  $c = 33$

(c)  $x = -2$

(d)  $x = 20$

(e)  $y = 4$

(f)  $x = -8$

(g)  $y = \frac{13}{4}$

(h) The solution is all real numbers.

(i) No solution

(j)  $x = 3$

11. (a)  $h = \frac{A}{\pi r^2}$

(b)  $s = \frac{B-A}{Br}$

(c)  $b = y - mx; b = 8$

(d)  $l = \frac{P-2w}{2}; l = 5$

12. (a) 11centimeters

(b) -4

(c) 13, 14

13. (a) 420

(b) 320

(c) 25%

(d) 45

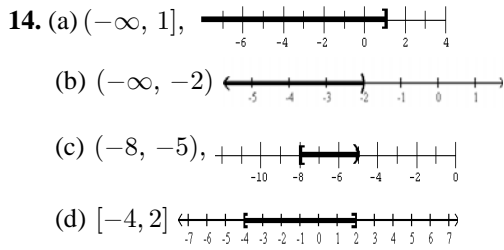

15. (a) **1** Week 4; **2** Week 2, 3, and 6  
 (b) **1** December (Month 12); **2** February (Month 2)

16. (a) A(4, 3), B(-4, 6)  
 (b)

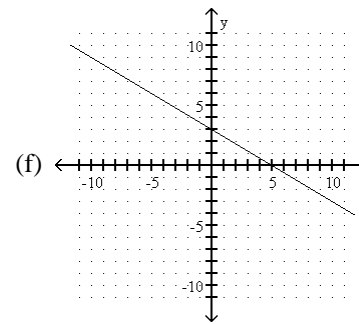
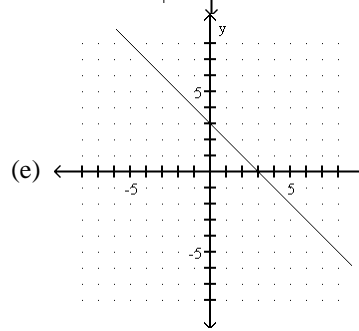
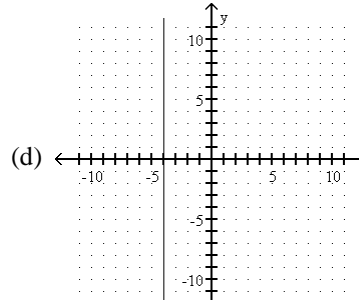
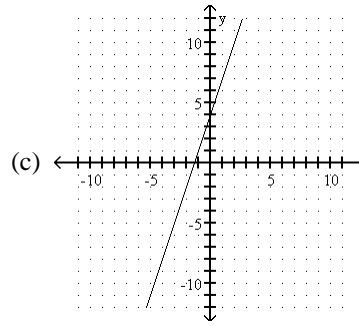
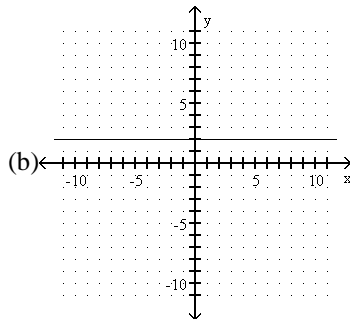
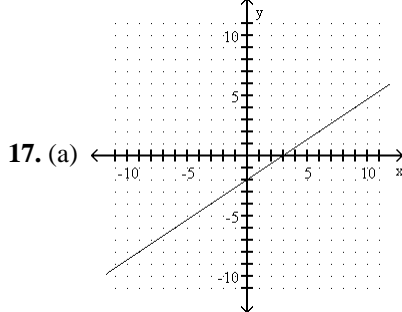
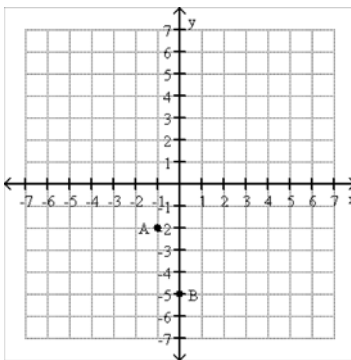

18. (a)  $x$ -intercept: (1, 0);  $y$ -intercept: (0, -5)  
 (b)  $x$ -intercept: (1, 0);  $y$ -intercept: (0, -1)  
 (c) (2, 0)  
 (d) (0, 3)
19. (a) -4  
 (b)  $\frac{1}{5}$   
 (c) undefined  
 (d) 0

20. (a) perpendicular  
 (b) neither  
 (c) perpendicular  
 (d) parallel  
 (e) perpendicular

21. (a)  $-8$   
 (b)  $-3$   
 (c)  $1$

22. (a) yes  
 (b) no

23. (a) Domain:  $(-\infty, \infty)$ ; Range:  $(-\infty, \infty)$   
 (b) Domain:  $(-\infty, \infty)$ ; Range:  $(-\infty, 2]$   
 (c) Domain:  $\{1, 2, 3, 4\}$ ; Range:  $\{2, 3, 4, 5\}$   
 (d) Domain:  $\{-4, -3, -2, 0\}$ ; Range:  $\{-1, 0, 4\}$   
 (e) Domain:  $\{x|x \text{ is a real number}\}$ ;  
 (f) Domain:  $\{x|x \text{ is a real number and } x \neq -\frac{1}{2}\}$ ;

24. (a)  $(3, 6)$   
 (b)  $(-1, 2)$   
 (c)  $(7, -8)$   
 (d) no solution  
 (e)  $(8, -2)$   
 (f)  $(-\frac{7}{17}, -\frac{77}{17})$

25. (a)  $\begin{cases} x + y = 12 \\ x - y = 2 \end{cases}$   
 (b)  $\begin{cases} x + y = -5 \\ 3x - 4y = 0 \end{cases}$

26. (a) leading coefficient:  $-9$ ; degree:  $5$   
 (b) leading coefficient:  $3$ ; degree:  $13$

27. (a)  $12x + 3$   
 (b)  $7x^2 + 5x + 11$   
 (c)  $10x^2 + 6x + 3$   
 (d)  $6x + 3$   
 (e)  $7x^2 - 5x - 7$   
 (f)  $4x^2 + 12x + 7$   
 (g)  $2x^5 + 5x^4$   
 (h)  $x^2 + 5x + 6$   
 (i)  $9x^2 + 6x - 8$   
 (j)  $5x^2 + 24xy - 5y^2$   
 (k)  $x^2 - 4x + 4$   
 (l)  $x^2 - 9$   
 (m)  $\frac{6}{st} - \frac{5}{r}$   
 (n)  $2x - \frac{5}{4} - \frac{y}{x}$

28. (a)  $3.7 \times 10^4$   
 (b)  $4.5 \times 10^{-5}$

29. (a)  $97,000$   
 (b)  $0.000097$

30. (a)  $-294$   
 (b)  $-6a^6$   
 (c)  $z^{12}$   
 (d)  $\frac{2}{y^5}$   
 (e)  $\frac{y^2}{x^4}$   
 (f)  $81a^{32}b^{24}$   
 (g)  $x^{15}$   
 (h)  $\frac{1}{9}$   
 (i)  $1$   
 (j)  $9y^8$   
 (k)  $\frac{27a^3}{b^3}$   
 (l)  $z^{15}$